



INGENIO WORKING PAPER SERIES

Ingenio

CSIC-UPV

INSTITUTO DE GESTIÓN DE LA INNOVACIÓN Y DEL CONOCIMIENTO



Whatever works: uncertainty and technological hybrids in medical
innovation

David Barberá-Tomás, Davide Consoli



Working Paper N° 2011/12

Whatever Works: Uncertainty And Technological Hybrids In Medical Innovation

David Barberá-Tomás¹, Davide Consoli

INGENIO (CSIC-UPV), Universitat Politècnica de València, Camino de Vera s/n,
46022 Valencia, Spain

(This version: November 2011. Please quote as: D. Barberá-Tomás and D. Consoli (2012) "Whatever works: Uncertainty and technological hybrids in medical innovation". *Technological Forecasting and Social Change*)

Abstract

The persistent uncertainty that looms over the search for solutions to health problems offers important conceptual insights for the study of technological change. This paper explores the notion of hybridization, namely the embodiment of multiple competing operational principles within a single medical device, as strategy to deal with the practical shortcomings due to said uncertainty. The history of the development of the hybrid artificial disk affords the elaboration of an alternative view of hybridization and, at the same time, the articulation of a dualism between medical science as area of basic research (e.g. what disease is) and as practical knowledge (e.g. how disease can be tackled).

Keywords

Medical innovation, Hybridization, Uncertainty, Technological evolution, Implantable medical devices.

¹ e-mail: jobarto@ingenio.upv.es INGENIO (CSIC-UPV), Universidad Politècnica de Valencia, Camino de Vera s/n, 46022 Valencia, Spain. Tel: +34 963 877 048; Fax: + 34 963 877 991

1 Introduction

Over the last two decades scholars of technological change ventured in the study of innovation in the health-care realm. Seen through the lenses of this novel approach medical innovation has been removed from the shadow of the ‘linear model’ framework that dominated science and technology studies in the early 1960s and cast under a new light. In a nutshell medical innovation is now understood as the outcome of a long-term learning process and analysed with a view to appreciate the incremental nature of a process unfolding in real time and under the uncertainty that typically, at least within innovation studies, underlies the translation of cognitive abilities into effective routines [1, 2]. The explicit recognition of temporality calls attention to path-dependence and the associated effects of advancing technological paradigms in locally familiar directions under the dual penumbra of positive increasing returns as well as the risk of lock-in within dynamically inferior configurations [3, 4]. In this view the growth and application of knowledge are bound, for good or for bad, to the “grip of history” (see [5] for a review). It follows, paraphrasing Simon [8], that the search for effective diagnostic and therapeutic avenues entails the pursuit of clearly defined goals through ‘procedurally uncertain’ routes [9,10].

This paper seeks to draw on and contribute this debate by analyzing the hybridization of a medical device, namely the artificial disk that is implanted surgically to alleviate from the painful symptoms of Degenerative Disk Disease - a leading cause of back pain and disability worldwide. This case study affords the opportunity to explore the conceptual underpinnings of hybridization (viz. embodiment of competing operational principles within a single device) understood here as evolutionary response to persistent uncertainty about both the nature of disease and the comparative clinical performance of available therapeutic solutions. The analysis of the long-term development of the hybrid

artificial disk elucidates broader aspects of medical innovation and, in so doing, contributes various strands of scholarly debate. First, the present paper suggests a novel perspective on hybridization, namely that making ‘available’ different operational principles within a single device allows leaving some room for adjustments should future reconfigurations be warranted by enhanced scientific understanding [11]. This nuanced view of engineering epistemology [12] overcomes narrow interpretations of the concept of technological paradigm observed in past literature[13], in particular for what concerns the incommensurability of competing principles [14]. Second, the case study shows that different approaches to know-how can be effectively combined and compensate, at least partially, for limited know-what. Last but not least the paper makes an important addition to the growing catalogue of case studies on the dynamics of innovation in medicine [15, 16, 17, 18, 19, 20] by restating forcefully the sheer variety of routes through which the process emerges and develops in this realm.

The remainder of the paper is organized as follows. Section 2 articulates the main conceptual elements of an evolutionary framework for knowledge growth and hybridization in medicine. Section 3 offers an overview of the scientific, clinical and technical aspects of uncertainty in Arthroplasty, the surgical implantation of a device to alleviate from the painful symptoms of Degenerative Disk Disease. Section 4 analyses in detail the development of the hybrid artificial disk and illustrates the fundamental relationship between hybridization and uncertainty. The last Section concludes and summarizes.

2 Background

2.1 *Uncertainty and medical innovation*

Commenting on the characteristics of innovation in medicine Richard Nelson [7, 21] argues that clinical routines are often implemented out of direct observation and in the face of imperfect understanding of the workings of disease. That is, the complex biochemistry of the body can at best guide the search process but the activities that are ultimately adopted in the clinics stem from recursive application in the course of providing patient care. What is more, clinical procedures not necessarily based on solid understanding of disease unpredictably reveal promising directions for basic scientific research.² In other cases observation of particular symptoms delimits the design space of therapeutics even though little is known about the aetiology of disease. In all these circumstances scientific instrumentation is crucial to enabling replicable experimentation for validating or refuting any particular solution [22].

The suggested functional separation between basic scientific knowledge – aimed at elucidating ‘know-what’ – and practical knowledge – viz. know-how for problem solving – places this perspective far from the traditional tenet of studies on health technology diffusion [7, 23, 24]. In recent years a stream of work along this alternative approach elucidated important nuances of the division between scientific and practical knowledge in medicine. Therein a central role is assigned to practical know-how besides standard clinical and surgical practices and aimed at improving the design and

² A paradigmatic case is the pioneering research on glaucoma carried out by Von Graefe in the mid XIX Century. He noticed that patients suffering congestive glaucoma experienced remarkable reduction of corneal ulceration after the iridectomy, which is a surgical incision aimed at reducing excess pressure within the eye. These clinical experiments led Von Graefe to conjecture a causative association between the congested appearance of the eye and the hypersecretion of aqueous humor which, eventually, became the basis for the Intra Ocular Pressure paradigm, a long-standing clinical framework for glaucoma diagnosis and treatment [17:38, 18]. This is a clear instance in which a clinical practice based on the explorative assessment of a surgical incision preceded and guided successive scientific inquiry.

use of implantable *devices* such as the intra-ocular lens [15], the stents for coronary artery disease [16] and the Left Ventricular Assist Device-LVAD [20]. What is common across these accounts of technical change in medicine is the blending of technical know-how on the properties of the materials or the mechanic behavior of implantable devices³ with clinical know-how (Figure 1). The latter, in turn, embodies the intertwining of clinical (interventional) procedures⁴, viz. surgical approaches, which make device implantation physically possible and, more relevant to our case, testing in a clinical setting, via experimental trials or regular surgical use, which provides crucial feedback about the unpredictable and complex interaction between technology and the human body [25].⁵

This perspective suggest a connection between research on medical innovation and particular episodes in the history of engineering brought to the general attention by the works of Constant [26] and Vincenti [27]. The bridging concept is that of an autonomous professional epistemology, that is, a body of technical know-how not subservient or derivative of science. This engineering epistemology⁶ instead blends the concept of scientific paradigms by Kuhn [29, 14, 30] with the notion that technological knowledge stems from recursive practice in design and testing. The outlined framework

³ For example, the durability of polyurethanes, of biological compatibility of acrylic glass and of rigidity of PVC have been crucial for the development of the LVAD, the intra-ocular lenses and the balloon catheter, respectively [20, 15, 16].

⁴ The National Institute for Health and Clinical Excellence (NICE) defines the ‘interventional procedure’ as a “treatment that involves ... making a cut or a hole to gain access to the inside of a patient's body”. From <http://guidance.nice.org.uk/IP>, retrieved 29 January 2001.

⁵ In a study on coronary artery disease Mina et al. [16] highlight the pivotal role of the Benestent and Stent Restenosis clinical trials of the early 1990s. These provided persuasive evidence of the advantages of stenting as opposed to ‘simple’ balloon angioplasty. Similarly Morlacchi and Nelson [20] emphasize a multi-center trial carried out in the late 1960s that confirmed the clinical use of Left Ventricular Artificial Device in supporting the circulation of patients for longer periods compared to temporary blood pumps. In the case of the intraocular lens, Metcalfe et al. [15:1290] underline the clinical studies of the early 1970s that showed dramatic reduction in time lost by the patient using phaco-emulsification, “the technique that transformed cataract surgery”.

⁶ We understand here epistemology in the Popperian sense: “the central problem of epistemology has always been and still is the problem of the growth of knowledge” ([28], quoted in [27:17]).

falls squarely in the variation-selection model of Vincenti [27, 31]: design activities spur a variety of solutions in the face of uncertainty about “what works” [32] while testing activities act as selection operators. In turn these design-testing dynamics create knowledge that is corroborated in practice but need not be necessarily grounded in a proven scientific notion [33]. This evolutionary view captures the essence of the division of medical know-how (when dealing with implantable devices) between clinical and design knowledge⁷: design of medical devices is mainly concerned with “purely” technological dimensions such as the properties of implantable artifacts while testing are crucial to guarantee safety and efficacy in the clinical realm (Figure 1).

- Figure 1 -

It is important to distinguish between the clinical environment and the particular operative conditions of laboratory trials on synthetic or cadaveric models. In the latter the complexity of the body-technology relationship is reduced to facilitate development activities in a nested variation-selection sub-process [24, 27].⁸ On the other hand the “testing regime” [19] of the laboratory environment does not reproduce “real-world” selection [32, 33]. Indeed both the FDA and the Notified Bodies of the European Commission in Europe mandate that new-to-the-world implantable surgical devices are tested clinically on humans – under special experimental exemptions – before approval [35].

Previous studies about implantable devices deal with the consequences of uncertainty at the level of know-what, that is, of scientific understanding of disease. Therein practical

⁷ We are grateful to Paul David for pointing this out during a session of the Stanford Science, Technology and Society Seminar Series.

⁸ In the nested hierarchy of variation-selection processes a further level is in the “mind experiments” carried out by engineers [34].

knowledge is described as unfolding along an almost autonomous trajectory based upon the variation-selection model of generation and testing of new device designs with minimal guidance from the scientific knowledge of aetiology.⁹ In these instances the results from clinical testing play an important role in the evolution of practical ways to tackle disease (see footnote 4). The case study of the intervertebral artificial disc presented here affords the opportunity to focus on dual uncertainty, not only about understanding of disease but also about clinical testing for which there are hitherto no univocal performance criteria. This analysis elucidates the emergence of design strategies in the process of experimenting with new operational principles when the testing part of the variation-selection model is limited by clinical uncertainty. In the remainder of the paper it will be argued that hybridization of medical devices is one of such strategies.

2.2 Hybridization: evolutionary response to uncertainty

A look at previous literature reveals different postures on hybridization. The first stems from a wealth of recent empirical studies on hybrid vehicles. Dijk and Yarime [36] associate corporate strategies to different forms of firm behavior such as “pioneer”, “slow follower” or “skeptical”; Avadikyan and Llerena [37] elaborate a real options approach to study the investment behavior on hybrid cars. Common across these contributions is the emphasis on the strategic aspects related to hybridization while little attention is paid to the design activities involved in the development of those technologies.

⁹ For example, Morlacchi and Nelson [20:512] comment about the intra-ocular lenses case that the “breakthrough was not dependent upon any significant improvement in basic understanding of cataracts or the workings of the eye”.

Next to this is a strand of studies that considers the relationships between different elements of technological systems. A classic reference is Sahal's [38, 39] work on the *symbiosis* between different elements of technological systems such as the programmable calculating machine and the solid-state technology of the electronic computer. In a similar vein, a study on the Smart House case by Peine [40] elaborates on the notion of technological systems as environments where different paradigms can coexist, like those associated to information technology and the construction industry. Pistorious and Utterback [41:72] add an interesting nuance to the debate by conceptualizing different kinds of symbiosis and hinting to a special form of symbiotic relationship as 'hybridization' – referred, though, not to the relationship between *complementary* elements (like construction and ICTs within a Smart House) but rather between *competing* operational principles that fulfill the same function. Under this perspective hybridization is understood as epiphenomenon occurring over the transition of technological systems through different paradigms. These transitions take the form of *niche evolution*. Similar hints emerge from accounts of gas turbines portrayed as auxiliary device of steam turbines [42], or from studies on navigation technology where steam engines are depicted as auxiliary devices for the consolidated sailing ships design [43]. In all these cases hybridization is a temporary symbiosis between an incumbent technology and a new one, with the latter improving the performance of the former [41]. At times the new technology further develops within the niche like steamships which eventually eliminated sails; other times the symbiotic relationship reverses the functional relation like in the case of co-generated power stations where gas turbines became the main component and steam turbines the auxiliary device.

The present study proposes a different view of hybridization not grounded in the niche dynamics of technological systems but, rather, connected to the concept of operational

principles.¹⁰ The latter, according to Murmann and Frenken [44: 939] facilitate the systematization of a set of artifacts into general product classes on the basis of “the kind of knowledge a human designer must have in order to build a technological device that works on the physical world in a desired way”. It is clear that hybrid technologies have hitherto been portrayed mostly as intermediate steps in the process of adjusting existing technologies systems to novel emergent criteria through niche evolution [43]. Our empirical analysis of the evolution of the artificial intervertebral disk expands on this while, at the same time, accounting for functionality and uncertainty. To begin with, we argue that technological systems are a special kind of artifacts, complex enough to contain different niches. The analysis of hybridization presented here focuses on a simple artifact, as opposed to large distributed and multi-component systems such as those for transport or electricity, with a view to illustrate the how functionally competing operational principles come to coexist outside of traditional frameworks such as niche dynamics. Secondly the niche perspective is often associated to energy-generation systems (e.g. for transport or manufacturing) where “demonstration effects” are easier to conceive and measure [45, 46].¹¹ In the case of the intervertebral artificial disc the absence of clear results about clinical performance implies that hybridization is a sound and persistent design strategy. This proposition resonates with Mokyr’s [11] suggestion that making “available” different operational principles within a single

¹⁰ For example, the principle underpinning human flight proposed by Cawley in 1809 was to “separate lift from propulsion by using a fixed wing and propelling it forward with motor power” – put another way, moving a rigid surface through resisting air provides the upward force necessary to counter gravitational force.

¹¹ One of such “demonstrations” was a bet about the performance of the first full-scale working railway steam locomotive in Pennydarren, in 1804 [47]. Looking at more recent cases, Islas [45:134] mentions gas turbines being introduced in the energy system of airplanes as a special application that allowed 35% improvements in output power. A related concept in the literature on techno-economic paradigms is the “big-bang” at root of long wave developments. Pérez [48] for example claims “big-bangs” coincide with demonstrated performance improvements in the application of energy to transport or manufacturing activities.

device to minimize and manage uncertainty.¹² The rationale is: if it works and until new problems come to surface jointly adopting several operational principles suffices and allows leaving room for future reconfigurations, perhaps after the veil of uncertainty has been lifted.¹³ Stated differently, the traditional view of hybridization as temporal symbiosis within a niche in conditional logic language would go: “If the new operational principle has demonstrated its competence in one element of the system, then use it”; in the view proposed here instead hybridization has a more general flavor and is functionally biased by uncertainty: “if you do not know which operational principle is better, then choose all”.

We believe that this nuanced view of engineering epistemology [12, 49, 40] overcomes narrow interpretations of the concept of technological paradigm. In fact rather than accepting incommensurability of competing principles along the canonical terms suggested by Kuhn [14] our view highlights the potential benefits stemming from the combination of different approaches to know-how towards a single solution, a medical device in this case. Thus contrasting Kuhn we suggest that “proponents of competing paradigms may practice their trades in the” *same* world [14: 150]. The evolutionary nature of this particular technical solution resonates with Stark’s [50: 164] insight on the generative role of diversity whereby “rivaling performance criteria [...] contribute[s] to

¹² Mokyr acknowledges that the set of “available” operational principles in the face of changing environment is “not a just a set of blueprints that firms and individuals can pick and choose from freely, but an underlying knowledge set, far more complex and multidimensional” [11:131].

¹³ Our concept of hybridization differs slightly from the “availability” concept of Mokyr who uses “junk” DNA as an example. DNA contains big parts of “junk” code, in the sense of not having any apparent function in the phenotype. But when environmental conditions change these DNA parts turn out to be “useful”: “The human gene uses only about 1 percent of the DNA; the rest seems to fulfill no obvious function, but changes in it may at some point in the future become useful” [11:123, note 7]. In the view presented here the operational principles joined in the hybrid device are seen as having more than purely random possibilities of success.

adaptability by preserving a more diverse organizational gene pool”.¹⁴ Let us now frame the analysis of hybridization in the case of the artificial disc.

3 Uncertainty and the artificial disc

In section 2.1 we sketched the contours of a framework where variation in design was a response to uncertainty. This section illustrates how in the case of artificial disc uncertainty refers not only to fundamental know-what about disease but also to know-how on clinical testing that is essential for the selection of the devices.

The appearance of the artificial disc in spinal surgery marks a significant step of scientific, social and economic importance in modern medicine. This prosthesis device is implanted in the spine to treat Degenerative disc disease (DDD), a physiological affection of the discs between vertebrae. The latter is recognized as the main cause of back pain and disability among adults in the United States whose associated costs have been estimated around £ 1.6bn in the UK [51] and \$26 billion in the US [52].¹⁵

After an experimental phase in the late 1960s a surgical technique to implant the artificial disk appeared in Europe around the late 1980s under the name of arthroplasty. This became an alternative to arthrodesis, or osseous fusion – the gold standard for the treatment of DDD consisting in the replacement of the disc with an osseous bridge between adjacent vertebrae (Figure 2).¹⁶ Though not yet at a mature stage the market for artificial discs has experienced considerable growth and is estimated to reach 3 billion

¹⁴ We thank an anonymous referee for calling our attention to this work.

¹⁵ The significance of DDD is well outlined in an editorial by Weiner [53:474]: “Despite the significant improvements in the treatment of many pathologic processes witnessed over the past century, some particularly difficult medical problems persist. These problems are characterized by unclear underlying etiologies and less than desirable outcomes of treatment in the face of considerable intellectual and financial investment. Examples include (...) degenerative disc disease. This latter problem (...) is particularly important given the societal repercussions – disability, work absenteeism, and health care costs (in the billions of dollars) associated with it are considered at ‘crisis’ level.”

¹⁶ The physiology of DDD in the lumbar and the cervical area are very similar, and so are the prostheses.

dollars volume and to progressively overtake arthrodesis as standard clinical practice [54, 55].

- Insert Figure 2 around here.

A look at the specialized scholarly literature suggests wide diversity of views about the nature and the pathogenesis of DDD [56].¹⁷ There is a kinematic theory strongly focused on the movements of the spinal disc which does not take into account the forces that produce the motion. On the other hand there is a dynamic theory that is mostly concerned with the combined effect of motion *and* loads.¹⁸ According to the former, back pain is a consequence of abnormal movements in the disc affected by DDD, and artificial disc replacement restores normal mobility [57]. According to the latter theory the dynamic properties of the anatomic disc, and specifically the load absorption of the cartilaginous articulation, play a crucial role in triggering the disease. To mimic anatomic load absorption, this theory goes, the artificial disc should reproduce the viscoelastic properties of a healthy disc. Both kinematic and dynamic theories about the sources of back pain signal intervertebral fusion or arthrodesis as an inappropriate surgical treatment for DDD, as they argue that the rigid nature of the bone bridge may trigger biomechanical alterations which ultimately can cause degeneration in the adjacent discs (the so-called ‘adjacent disc degeneration syndrome’) and the need for further surgery [58].

¹⁷ Besides the biomechanical explanation a purely chemical explanation refers to the pain-provoking chemical changes of the discs during the degeneration process [56].

¹⁸ An extreme version of this has been proposed by Mulholand [57], namely that loads are the only biomechanical cause of pain in the disc, and that movement related causes are “a myth” that has dominated spinal biomechanics for the last 30 years.

Although early hints at the dynamic aspect of disc functionality date back to the early 1970s [59], uncertainty persists about the actual importance of load absorption. Difficulties in measuring load absorption both *in vivo* and in laboratory environments are the main cause of chronic paucity of data about the properties of the intervertebral disc [60:347]. To the best of our knowledge, only one laboratory study set out to analyze the impact of load absorption by means of invasive force sensors installed in a cadaveric model of spine units [61]¹⁹.

Deficient knowledge on the workings of the natural disk affects also the design of the artificial device that is supposed to replace it. The history of DDD treatment is in fact a tale of how this uncertainty has become a focusing device for designing a clinical solution. The first artificial disk to be adopted for clinical use was built on what we refer to as ‘hip-like’ operational principle, a ball-and-socket mechanism developed originally for hip prostheses by Sir John Charnley in the 1960s [62]. The principle underlying this device, substituting the hip articulation with a prosthetic implant, is one of the most successful surgical inventions of recent times as confirm the widespread adoption for the treatment of other articulations, such as knee and shoulder²⁰. These developments were pivotal in bolstering both orthopaedic surgery and the implants industry [64]. The SB Charité hip-like artificial disc for the spine was the first to be commercialized in 1987 in Europe and, after 2004, in the US. These artificial discs feature rigid contact surfaces in the form of a ball-and-socket articulation made of material akin that of hip

¹⁹ In the words of an artificial disc designer: “You cannot put a sensor in an *in vivo* environment to measure load absorption. And that means that, at best, you can only have *in vitro* data for this property in the healthy, degenerated and artificial disc. And you cannot trust only in *in vitro* data since these are highly dependent on the specific design of the laboratory experiment”. Furthermore, laboratory experiments simply cannot reproduce some conditions of the *in vivo* environment: “The dynamic load-response behavior of the anatomic disc could depend even of the hour of the day, and you cannot reproduce that with cadaveric specimens”. This stresses the crucial importance of clinical testing in the variation-selection process of adoption of new designs of implantable devices, pointed in Section 2.1 of this paper.

²⁰ This “lineage development” [63] of a technology outside its original domain of application is typical of technological evolution. We thank an anonymous referee for pointing this out.

prostheses, i.e. metal or relatively rigid plastic such as UHMWPE (Figure 3). Although these discs enhance mobility of the intervertebral segment, their rigid surfaces prevent effective load absorption [60].

- Insert Figure 3.

The alternative operational principle to ‘hip-like’ is the ‘mimetic’, adopted first in Europe in 2007 while still awaiting approval in the US. Although mimetic discs are late entrants in clinical use numerous R&D projects contributed to perfect this operational principle especially in the US [65]. Mimetic-type artificial discs are designed to replicate the articulation of the anatomical disc not only for what concerns movement but also for load absorption (Figure 4). As anticipated earlier however since the effective impact of load absorption for both natural and artificial discs has not been established with certainty, opinions concerning these operational principles go both ways. Advocates of the hip-like disc maintain that the absorption of load in the anatomical disc (if it exists) is irrelevant and that prosthetic restoration of movement suffices [66]. Conversely advocates of the mimetic disc argue that disregarding load absorption generates biomechanical problems and painful symptoms that often end up with further surgery [58].

- Insert Figure 4

Besides this basic uncertainty concerning load absorption, there is also a fundamental uncertainty about the differential clinical performance of the mimetic and the hip-like

discs. To the best of our knowledge, no clinical or laboratory study of any type has so far been set to compare the performance of the two principles of artificial disc. This is possibly because specialists are preoccupied by an even bigger task, that is, proving the efficacy and safety of the whole artificial disc rationale compared with the surgical gold standard of arthrodesis, or bone fusion of two vertebrae through the intervertebral space (see Figure 1). This task has been proved difficult: in the randomized studies carried out so far and, although disability and quality of life scores tip in favor of arthroplasty, no evidence can be said to support conclusively either procedure.²¹

Thus, there are two fundamental uncertainties derived from testing. The first stems from the difficulty of measuring load absorption in the disc – be it healthy, diseased or artificial. And, second, a lack of tests aimed at measuring the comparative performance of different operational principles of disc prosthesis. The contested terrain here is the comparison with arthrodesis which continues to attract resources and attention.

In our view these two fundamental uncertainties triggered different responses concerning the variety of artificial designs. The first response paved the way to the mimetic/hip-like variants, since uncertainty about the concrete amount of load absorption stands behind the decision to either incorporate this property in the device configuration (mimetic) or not (hip-like design). The second response adds the hybrid design to the mimetic/hip-like repertoire, and relates to testing uncertainty about the

²¹ In its evidence-based guidance for the use of the artificial disc of both 2009 and 2010, the National Institute for Health and Clinical Excellence (NICE) identifies 5 randomized controlled trials comparing the efficacy of artificial disc and fusion. In 4 of 5 of these studies the differences were non-significant at the end of the follow-up. This circumstance affected the launch of the artificial disc in US in 2005, where many insurance companies, as well as Medicare and Medicaid, initially authorized only very limited or no reimbursement at all for performing the procedure in the United States “due to the lack of good evidence of long-term clinical benefit and safety” [67:329] even after the FDA approved trials. Although reimbursement of artificial disc is now broader, this issue is still one of the most important hurdles in the adoption of this technology in US.

clinical differential performance of these two competing principles. In next section we propose this uncertainty is crucial in the rationale of the hybrid design.

4 Hybridization and the artificial disc

4.1 A case study about the hybrid disc

This section outlines the basic design principles and the steps that led to the definition of the Bryan artificial disc, the only hybrid device that has been approved for clinical use.²² Let us begin by noting that the dualism between the hip-like and mimetic operational principles is a recurrent theme in the specialized medical literature. A survey article by Bono and Garfin [56] refers to ‘articulated non-elastic discs’ and ‘elastic discs (with load absorption)’. Also Lee and Goel [58] mention ‘kinematic discs’ and ‘kinematic and absorption of load discs’ while Szpalski et al. [65] talk about ‘artifacts destined to restore the kinematic functions’ and ‘... to restore the viscoelastic functions’ respectively. Interestingly only the latter study acknowledges that the history of the artificial disc features ‘some devices [that] attempt to combine both principles’ [65:S67]. Hints at hybridization can be found also in patent n. US5314477 that mentions the possibility of a “combination of these two research routes” in the design of the artificial disc, and in patent n. US7563286 whose classification of disk devices includes a hybrid category with different design principles.

To appreciate the hybridization trajectory we take a look at the circumstances underpinning the development of the Bryan artificial disc. The *clinical* origins of this venture are mentioned in a published interview with Dr. Bryan, a spine surgeon [68]:

²² The technical specifications presented here have been validated through interviews with four experts. One of them was involved in the development of the Bryan disc in late 1990s; another was involved as a design engineer in one of the most important mimetic projects of the late 1980s, the Acroflex artificial disc. The other experts are R&D engineers currently working in new artificial disc developments, one hip-like and the other mimetic.

“In North West there is a very young population which is very active in outdoor activities, whether mountain climbing, topping trees, fishing and so on. Many young people present to us with ... early degenerative changes in their spine and get operated with the usual operating procedure. Then these people are coming to us after 5/6 years and in a significant number of them, we find ourselves re-operating... So I have been thinking of this for many years”. Seeking engineering advice, Bryan joined forces with Alex Kuntzle, a mechanical engineer from the metallurgic industry. After a patent application in 1994 they sought venture capital to fund Spinal Dynamics a start-up to develop a spinal disk device. The company was subsequently acquired by Medtronic Sofamor Danek (MSD) for 269.5 million US dollars at the beginning of the 2000s. The Bryan disc received approval for clinical use for Europe in 2001 and in 2009 for the US [69, 70]. It has been estimated that up to 2010 the Bryan disc has been used in about 35000 surgeries.

The thrust of this venture, Dr. Bryan claimed, was seeking “to change the nature of the joint from an arthrodiar joint to restore something similar to diarthrodial joint” [68:8].²³ While this statement refers to a hip-like principle, Dr. Bryan also claims that the artificial disc should provide “cushion as the normal vertebral disc” [68:8], the latter being a distinctive property of mimetic design. To confirm this, patent No. US7025787 (by Bryan, Kuntzler et al owned by Medtronic) claims that the implant “should also provide elasticity and damping sufficient to absorb shocks and stresses imposed on it in a manner similar to that of the natural disc”.²⁴ Patent No. 7025787 (2002) presents the

²³ Diarthrodial joints (or synovial joints), such as hip or knee, joints are freely moveable; Arthrodiar joints (or cartilaginous joint), as the spinal disc, only allow for limited movements.

²⁴ In this patent also is stated that the goal of the invention is to transform a natural arthrodiar joint like the spinal disc in an artificial diarthrodial joint.

salient features of the Bryan artificial hybrid device: one elastomer²⁵ and two small metal plates that act as disc-bone interface to ensure stability. These specifications suggest close similarity with the mimetic Acroflex disc (Patent No. US5071437) (see left-hand side of Figure 5) the outcome of an important venture in the orthopaedic implants industry in the 1980s.

- Insert Figure 5.

Early tests of this device highlighted both in the laboratory and in human trials repeated failures of the elastomer, the component that is expected to provide load absorption and motion [65, 67]. This occurrence proved crucial for the conception of the Bryan Disc whose layout features an important variation compared to the basic mimetic configuration: the small plates are allowed to rotate around the elastomer thus creating a ball-and-socket articulation similar to hip-like discs (Figure 5, right-hand side). The mimetic operational principle instead features small plates joined to the elastomers, in a 'sandwich configuration' that does not allow rotation (Figure 5, left-hand side). The existence of elements of both operational principles in the design of the Bryan disc is also signalled by the citations of US -the first patent associated to the Bryan disc- which include both mimetic (as US4911718) and hip-like (DE3023353) patented designs.

The Bryan disc, it is worth stressing, was conceived against the backdrop of a debate about the performance of the sandwich configuration of the mimetic principle and the initial positive performance of the hip-like device. As a matter of fact, hip-like disks gained momentum in the early 1990s after diffusion of negative results of experimental

²⁵ Elastomer refers to materials with mechanical properties (e.g. hysteresis) similar to rubber.

clinical trials with the Acroflex disc [71] and of positive feedback from non-randomized trials of the SB Charité disc – a lumbar hip-like design [72].²⁶ Shortly afterwards the Frenchay hospital in Bristol, UK, one of the most prestigious centres in the world for neck surgery announced positive experimental results on humans with a cervical hip-like prosthesis [73].

- Insert Figure 6 around here.

Let us offer a functional analysis of the technical aspects involved in the evolution of the hybrid disk. Figure 7 represents the design trajectories of hip-like, mimetic and hybrid principles. To highlight design characteristics we refer to what Ulrich [74] calls the “iota level”, viz. the individual pieces.

- Insert Figure 7 around here (figure 7 at the end of the paper).

Early prototypes of the artificial disk featured steel (Fenström; Reitz and Joubert) or silicone spheres (Nachemson; Fassio and Ginestie) aimed at improving mobility and load absorption (the silicone spheres) or mobility only (the stainless steel devices). It soon became clear that the spheres were not suited to reproduce the properties of cylindrical discs in supporting adjacent vertebrae (Figure 8). Bono and Garfin [56:147S] distinctively refer to those failures as lessons learned for future developments. One route in this problem sequence entailed the addition of two intervertebral plates between

²⁶ There are institutional differences between the clinical results coming from Acroflex and SB Charité’s first human implantations in the late 1980s. The former project was carried out by Acromed an US-based company which applied for a special IDE (Investigation Device Exemption) required by FDA to conduct experimental clinical trials on humans. SB Charité – developed by Waldemar Link, a German company – was implanted before the 1993 European regulation requiring similar trials for new devices [35]. The results reported in the early 1990s for SB Charité do not come from official experimental trials but from regular clinical use in Germany, Netherlands and France. In 2000, Waldemar Link started the FDA trials required for the regular implantation of SB Charité in US. In any case, both in the hip-like and mimetic designs results of the early 1990s involved human clinical testing, which is the selection part of the variation-selection process of new device emergence we are interested in.

the ball and the adjacent vertebrae to improve stability [56; 54].²⁷ In this second generation of hip-like artificial discs the ball-and-socket articulation is the component that affords mobility to the intervertebral space. In Figure 7, the ‘SB Charité’ and ‘ProDisc’ labels in the upper part coincide with the most representative designs among hip-like artificial discs. Subsequently additional problems guided the incremental transformation of the design to improve the performance of the ball-and-socket articulation (‘Prestige’ and ‘Maverick’ labels in upper part of Figure 7). In the mimetic principle (bottom part of Figure 7) two additional plates were attached to an intermediate elastomer to create the sandwich configuration that provides both mobility and load absorption. But the elastic layer impairs the stability of the implant, as demonstrated by repeated and unexpected failures in clinical testing of the Acroflex disc²⁸ which was followed by general distrust on this configuration. As mentioned earlier the mimetic design has the elastomer and the plate joined in the same mould, a feature that disregards relative rotation. This constraint creates excessive load on the elastomer with the risk of structural failure of the device [76]. The hybrid model appeared in the mid-1990s (central part of Figure 7) joins the ball-and-socket and the elastomer elements in a single device, thus providing mobility *and* load absorption like the mimetic principle but in a different way, since the vertebral plates are not joined to

²⁷ The addition of components to overcome the limitations of primitive and crude original prototypes is a typical phenomenon of early phases of technical invention. Arthur [75] describes it as “structural deepening”.

²⁸ The failures of the Acroflex were repeated as this device was tested in humans in three cohorts, in 1988-1989, 1993-1994 and 1998-2000 [67]. They were unexpected “given that the device was extensively tested in the laboratory and had easily withstood the range of described normal in vivo loads on the ... intervertebral disc” [76:248S]. This again (see footnote 18) stresses empirically the differences between laboratory and human clinical testing we assume in Section 2.1 variation-selection model.

the elastomer but articulated in a ball-and-socket joint. As a result the mimetic kind of failure of the elastomer is overcome by the hybrid design of the Bryan Disc.²⁹

- Insert Figure 8.

The hybridization of the artificial disk entailed a number of incremental ameliorative efforts. Part 70 in Figure 6 indicates a membrane attached to vertebral plates whose function is preventing migration of plastic particles from the hip-like articulation. The latter was a key salient since the particles provoked allergic reactions and resulted in systematic failure of hip implants. The adoption of special plastic support (UHMWPE) addressed this particular problem and consolidated hip substitution into one of the most successful surgical procedures worldwide. At the same time UHMWPE is a rigid plastic incapable of providing significant load absorption [60]. To accommodate this operating principle the Bryan hybrid design needed a more elastic material. Polyurethane, one candidate, raised concerns about the biocompatibility of the particles which were expected to provoke negative response compared to UHMWPE [78]. The Bryan design was eventually further modified by the inclusion of an isolating membrane that avoids the deleterious effect of polyurethane (Figure 9). Clearly the extra design efforts entail a growth in the complexity of the device, a familiar characteristic of hybridization according to other studies such as for example the hybrid car [36].

- Insert Figure 9 around here.

²⁹ The mimetic principle experienced a renaissance with 3 designs recently adopted for clinical use in Europe after 2008, and currently under analysis with experimental clinical tests for adoption in the US. [77]. This revival is due to the introduction of additives (polycarbonates) in the elastomers, a modification that seeks to improve the mechanical performance of elastomers and minimize the effect of the load constraints of the sandwich configuration (designs 'M6' and 'Freedom' in the lower-right corner of Figure 7).

The Bryan disc hit the European market in 2001³⁰ followed shortly afterwards by a number of hip-like discs. Sales data reported by Biondo and Lown [69] show that in 2004 the Bryan disc dominated 2/3 of the cervical disc market (2500 surgeries), while 1/3 was the share of the remaining 3 hip-like designs (1300)³¹. Figure 10 illustrates the sales volume of artificial discs worldwide between 2000 and 2004 [69]. It is estimated that so far as many as 35000 surgeries have been performed to implant the Bryan Disc, mostly in Europe. Although no data about production costs are available it is reasonable to expect that the Bryan hybrid device was no cheaper than hip-like disks. Indeed the preceding paragraphs suggest the complexity of the Bryan Disc whose design entails more components and assemblies compared to the “good old” technologies [79:2] based on the articulation concept of the hip prosthesis [62]. This resonates with the observation that surgeons are the ultimate decision makers and are strongly oriented by product quality. As Lieberman [54:610] points out, in the spinal implants market “price has become a secondary determinant of demand, only remotely involved because physicians, who function as the principle users, are not the typical final consumer”.

- Insert Figure 10 around here.

Let us sum up the technical configurations outlined this far. As the introductory section spells out hybridization is a design strategy aimed at making efficiently “available” all

³⁰ Artificial discs are used both in lumbar and cervical surgery. Although the size of the artifacts depends on the spinal area the patented designs usually refer to the spinal zone, with no distinction between cervical and lumbar prosthesis. In general the development of disc prostheses depends strongly on the capabilities of the surgeons involved. Bryan, for example, was mainly concerned with the cervical region. At the same time the technological principles of the Bryan disc are applicable both to the cervical and lumbar regions: in the patents the artifact is referred to as a “spinal disc endoprosthesis”, with no specifications of the anatomic region involved.

³¹ The Bryan disc was the second in a list of 9 lumbar/cervical artificial discs sold worldwide, only below the lumbar SB Charité, a hip-like design.

the operational principles that can be useful to confront the existing lack of comparative performance testing (as we have seen in Section 3) by bundling them together in a single artifact. As seen above, the hybrid Bryan device incorporates the known positive characteristics of the hip-like disc with the additional potential advantage of catering for load absorption. Table 1 compares synthetically the advantages and the disadvantages of the three principles discussed so far.

- Insert Table 1 around here.

4.2 Hybridization through time

This section illustrates the unfolding and co-existence of multiple trajectories in artificial disk technology. We implement connectivity analysis on patent citations data [16, 80, 81, 82, 83].³² These were collected by means of keyword search³³ from the USPTO database for patents granted until 2008. This returned 201 items which were subsequently parsed to extract cross-patent citations. We added citations to patents of other kinds of medical products to study the technological antecedents of the selected products [16]. Our final database includes 1535 patents and 6130 citations. The algorithm “Network of the Evolution of the Top Paths” (proposed by Verspagen [81] and applied in [83] and [82]) is used to gather citation sequences among the most

³² We use US patents for our artificial disc search as they are the only ones used in connectivity analysis so far. This geographical bias has to be acknowledged), since Europe played an important role in the history of the artificial disc. We tried to capture the influence of European developments in our history of the artificial disc. However, the large majority of US’ patent shares (160 of the 201) for artificial disc seem to belong to a seemingly ‘autonomous’ trajectory. These 160 patents belong to patent families associated to a US priority date or to a WIPO priority date applied first in North America. Also, 112 of these 160 patents have European ‘offspring’ indicating that invention activity in the US has been influential in Europe while there is no reciprocity in this influence: of the original 201 patents only 41 have an ex-US origin [84].

³³Key words searched in the title and the abstract of the patents: “disc prosthesis”, “artificial disc” and “arthroplasty”.

important patents on the artificial disc which form the top path (labeled with red color in Figures 12, 13 and 14). We consider important patents those that result in a product that is in use. The top path contains a higher proportion of those patented developments, leaving the other branches (labeled with yellow color) to be dead-ends where technology did not advance [81,83]. Figure 11 offers a synthetic summary of the growth of the three operational principles in the network, and depicts the temporal evolution of the 53 patents that make up the “network of the evolution of the top paths” algorithm shown in Figures 12, 13 and 14. Details of the corroborated validity of connectivity analysis applied to artificial disc patents are provided in Barberá et al. [84].

- Insert Figure 11 around here.

Looking at the citation network three patent groups stand out: hip-like (squares), mimetic (circles) or hybrid (triangles). We previously mentioned that the first phase of the evolution of the artificial disc in the US (1973-1987, that is, prior to market introduction of the hip-like SB Charité, in Europe) was based on a mimetic design principle, labeled with red circles in Figure 12, which were important for early laboratory feedback about the simulation of the surgical procedure to hip-like developers. As anticipated above negative trial outcomes eventually led to the abandonment of mimetic disc projects. In the meantime as early positive outcomes of the hip-like operational principle were being published in Europe, US-based companies intensified efforts towards hip-like devices such as the Maverick Disc or the Prestige Disc. This change of direction can be observed in Figure 14 where the trajectory of the US top path diverts from mimetic to hip-like operational principle (red square patents) that dominates the top path after 1998.

Dead-end patents (yellow dots) in Figure 13 are included to illustrate the extent of trial-and-error during the period 1987-1997. Among these we note mimetic designs (yellow circle patents), hip-like designs (yellow square patents) and some hybrid configurations – the three yellow triangles enclosed by a blue dotted circle at the bottom of the figure. More specifically, patent No. US5674296 is the first associated to the Bryan disc project while US6001130 and US6156067 are continuations-in-part.³⁴ Figure 14 shows that this exploration in the hybrid terrain does not continue in the top path and turns towards hip-like patents after 1997.³⁵ Hybrid designs continue to flourish in the 1997-2004 phase but not in the top path. The figure indicates also various hybrid patents around the top path (enclosed in blue dotted ellipses) belonging to three³⁶ hybrid development projects (like in the Bryan patents, there were several continuations-in-part, so the 1997-2004 stage features more hybrid patents than hybrid projects).

- Insert Figure 12, 13 and 14 around here.

The analysis presented here illustrates the transition of inventive activity that led to the definition of the Bryan hybrid disk in the mid-1990s. This device emerged in a context dominated by the mimetic design between late 1980s and early 1990s and by hip-like design in the 1990s. It is worth stressing two important circumstances. It is important to

³⁴ Continuations permit an applicant to refill a pending patent application. Continuations-in-part are special kind of continuations which includes a substantial portion or all of the parent application and adds matter not disclosed in that application, although the benefit of early priority is awarded only for the original disclosures contained in the new application [85].

³⁵ The position of the last two hybrid patents in Fig. 11 is due to truncation of the patent data in the last years [81] and do not necessarily mean a shift in the importance of hybrid designs.

³⁶ One of these projects was finally approved for clinical use as a hip-like design. We include it in the hybrid operational principle because the patents associated to the project include, apart from the hip-like realization, other designs to include a load absorption effect.

clarify that this analysis is limited to inventive activity in the US since European developers traditionally favored devices based on the hip-like principle. Furthermore the present analysis focuses on the 1973-2004 period, indeed an intense one but certainly not the last chapter of the artificial disc technology – or several others for that matter. The mandatory note of caution therefore is that the technological trajectory under analysis is still unfolding and turns and further twists are a possibility.³⁷ To be sure over the last three years there has been a recent renaissance of mimetic designs that have been adopted in Europe and are under pre-approval trials in the US (see footnote 28 and lower-right corner of Figure 7). This circumstance is not reflected in our citations map, and it raises new thoughts about the adaptability of the hybrid discs: if the mimetic renaissance finally confirms the clinical superiority of this operational principle, it is reasonable to suppose that the hybrid disc is well-equipped to face the new situation, as its configuration presumably allows load absorption.

Transition perspectives sometimes concede little strategic value to hybridization. Utterback [86:191], for example, states that “bridging a technological discontinuity by having one foot in the past and the other in the future may be a viable solution in short run, but the potential success of hybrid strategies is diluted from the outset compared to rivals with a single focus”. Therefore viewed from the perspective of mid-1990s state-of-the-art among US specialists the “past” of artificial disc exploration consisted of a series of failed attempts within the mimetic logic while the “future” pointed at the hip-like design, while nowadays the favor seems to have tipped again for the mimetic principle. The essentially adaptive character of hybridization restates its value under radical uncertainty. Such a perspective resonates with nuanced views of technological

³⁷ We thank an anonymous referee for stimulating a thorough reflection on this point.

expectations that account for the strategic value of other real, common and ‘rational’ alternatives and that differ from the inevitability of embracing new technologies during technological transitions [87]. As Rosenberg [88] argued long ago, when the speed of technological change is high and some *future* major innovations are deemed plausible, the diffusion rate of the *present* new technology is delayed since adopters would rather wait for future improvements rather than being locked-in within a design that may soon turn out to be obsolete or inferior. Accordingly, the case study of the artificial disc suggests that persistent and radical uncertainty on the nature of disease poses serious limitations to the stability of design standards given that any new discovery may undermine the attendant logic of therapy. In such circumstances hybridization is a sound strategic response and not just a conservative option whose potential success (paraphrasing Utterback [86:191]) “is diluted from the outset compared to rivals with a single focus”. This is reflected also in the historical excursus presented above and, in particular, the circumstances behind the adoption of the hybrid artificial design among US developers in the early 2000s (see triangles enclosed by two blue dotted circles in Figure 14, also represented by the labels US7022139, US7067959 in the mid-right part of Figure 7). If indeed the recent renaissance of the mimetic disc driven by the arrival of new biomaterials (see footnote 28) holds sway and load absorption design turns out to be the ultimate “winner” in this ongoing battle, hybrid designs of the mid-2000s, which comprise components theoretically capable of absorbing load (labels US7022139, US7067959 in Figure 7), will likely be fitter to the new configuration compared to the contemporary hip-like artificial discs (labels ‘Prestige’ and ‘Maverick’ in Figure 7) with no absorption capacity.

5 Discussion and concluding remarks

This paper adds to the growing body of work on health technologies that received much attention among innovation scholars in recent times. The case studied here, the artificial disk, illustrates the extent to which design heuristics contribute to devising a remedy to a practical problem, back pain, in the absence of definitive knowledge on the nature of the cause (Degenerative Disk Disease) and on the comparative performance of the devices designed to alleviate its painful effects. Our analysis shows that search within a novel design space under the penumbra of imperfect understanding led to the proliferation of competing standards. Far from being the mark of a settled issue the recently-emerged artificial hybrid disk is a satisficing [89] solution to minimize the impact of the apparition of new therapeutic goals that may, or may not, come to surface once the veil of ignorance – concerning the disease and the clinical performance of the devices – is lifted. Hybridization of medical device therefore is the visible face of an inter-temporal externality between state-of-the-art and knowledge that is not totally proven but whose future discovery can be presumed [90]. Consistent with Mokyr's [11] claim that making available different operational principles mitigates the disruptive consequences of uncertainty, the prevailing rationale in disk surgery replacement has become: "If you do not know which operational principle is better, then choose all".

The present study argues that hybridization is an evolutionary strategy in the implementation of design solutions to ill-specified health problems. It is evolutionary in the sense that variety is generated in the face of uncertainty [91]. The prevailing body of practice is therefore understood as a dynamic learning process feeding on and bearing upon the broad knowledge bases that make up medical communities wherein operate scientists, practitioners, engineers as well as managers and policy makers [21]. Looking at this process through the lenses of history reveals that the long-term trajectory of

medical innovation does not resemble a punctuated succession of alternative paradigms but rather an incremental inter-penetration of different problem-solving styles wherein emergent courses co-exist with, rather than abruptly replacing, old ones [92]. To reiterate, this trajectory emerges as purposeful response to absence of conclusive indications on the nature of disease and consists in balancing “mutually coevolving yet not converging paths” [50: p. 26].

These issues carry broad relevance for the divide that exists in the problem spaces of medical science and practical knowledge. In the case at hand alleviating back pain entails, in principle, knowing the nature of the degenerative process in the spinal disk and devising a technique to reduce the physical discomfort that it causes. This unity of intents however subsides against practical reality. Medical know-what pursues general understanding of the neurochemical and physical properties of disk degeneration while clinical and design knowledge seek to develop useful artifacts and a set of stable routines. As patterns of specialization, research styles and professional goals deepen, ‘learning what disease is’ and ‘learning how to tackle disease’ unfold along distinct problem-solving trajectories. The necessity of offering a clinical response to an ill-understood disease induces forms of knowledge organization based on practical and identifiable problems rather than general chemical or biological principles.

Dynamics of this kind, Nelson [7] argues, place medical knowledge in the vicinity of engineering science more than had hitherto been realized and suggests careful reflection about the terms in which scholarly and policy discourses are couched. The foregoing analysis elucidates on purportedly complementary and yet perpetually parted domains of descriptive and prescriptive knowledge, the former indicating things as they are the latter how they should be to attain a desired goal [27]. Descriptive knowledge is assessed in terms of correctness, prescriptive knowledge in terms of degrees of success

or failure; but contrary to descriptive knowledge, prescriptive knowledge is open to deliberate adaptations to a prescribed end. By the same token, errors, unintended variations and unexpected consequences play a strong role in the progress of medicine. A key prerequisite to harness these lessons and overcome translational gaps, that is, bottlenecks that impede effective feedbacks between scientific, clinical and technological knowledge is the existence of institutional channels for facilitating the transmission of feedbacks. A great deal of hope about broadening the horizons of medicine rests in the prospect that these epistemological terrains may be effectively bridged.

Acknowledgements

A preliminary version of this manuscript was presented at the European Meeting of Applied Evolutionary Economics (February 2011. Sant'Anna School of Advanced Studies, Pisa) and at the Dynamics of Innovation and Markets in Europe (DIME) Final conference (06-08 April 2011. UNU-MERIT & School of Economics and Business, Maastricht University). On those occasions and others we benefited from the insightful comments and remarks of Paul David, Arianna Martinelli, Roberto Fontana, Carlos Montrós, Carolina Ávila and Rafael Albert. We also thank two anonymous referees for helpful feedback on earlier versions. Remaining errors and omissions are entirely our own. David Barberá-Tomás acknowledges the financial help of the 'Programa de Apoyo a la Investigación y Desarrollo (PAID-00-10)' and of the Facultad de Administración y Dirección de Empresas (FADE) at the Universitat Politècnica de Valencia (UPV). Davide Consoli acknowledges the support of the European Commission (FP7-PEOPLE-IEF-2008-235278) and the Leverhulme Trust research-fellowship scheme.

References

- [1] O'Driscoll GP, Rizzo MJ (1985) *The economics of time and ignorance*. Routledge, London
- [2] Consoli, D. and A. Mina, 2009. An evolutionary perspective on health innovation systems, *Journal of Evolutionary Economics*, 19(2): 297-319.
- [3] Arthur, W. B. 1988. 'Competing technologies' in: Dosi, G., C. Freeman, R. Nelson, G. Silverberg, and L. Soete (eds.), *Technical Change and Economic Theory*. London: Pinter, pp. 590-607.
- [4] David, P.A. 2000. Path dependence, its critics and the quest for 'historical economics' in P. Garrouste and S. Ioannides (eds), *Evolution and Path Dependence in Economic Ideas: Past and Present*, Edward Elgar Publishing, Cheltenham, England.
- [5] Castaldi, C., Dosi, G. 2006. The Grip of History and the Scope for Novelty: Some Results and Open Questions on Path Dependence in Economic Processes. In: Wimmer, A. and Kössler, R. (eds.) *Understanding Change. Models, Methodologies, and Metaphors*. London, Palgrave: 99-128.
- [6] Kline, S.J., Rosenberg, N., 1986. Overview of innovation. In: Landau, R., Rosenberg, N. (Eds.), *The Positive Sum Strategy: Harnessing Technology for Economic Growth*. National Academy Press, Washington, D.C., pp. 275–305
- [7] Nelson, R.R., 2003. On the uneven evolution of human know-how, *Research Policy* 32: 909-922.
- [8] Simon, H.A. 1969. *The Sciences of the Artificial*. MIT Press, Cambridge, Massachusetts.

- [9] Dosi, G., Egidi, M. 1991. 'Substantive and Procedural Uncertainty: An Exploration of Economic Behaviours in Changing Environments'. *Journal of Evolutionary Economics* 1(2): 145-68.
- [10] Consoli, D., McMeekin, A., Metcalfe, J.S., Mina, A., Ramlogan, R. 2009. The Process of Innovation: Incentives, Behaviour and Organization. In *The Economics of New Health Technologies: Incentives, Organisation and Financing*, ed. J. Costa-i-Font, C. Courbage and A. McGuire, Oxford University Press.
- [11] Mokyr, J., 1998, Induced technical innovation and medical history: an evolutionary approach, *Journal of Evolutionary Economics*, 8:119-137.
- [12] Stankiewicz, R. 2000. The concept of 'design space'. In J. Ziman (ed.) *Technological Innovation as an Evolutionary Process*, New York: Cambridge University Press, 234-245.
- [13] Dosi, G. 1982. 'Technological Paradigms and Technological Trajectories'. *Research Policy*, 11(3): 147-162.
- [14] Kuhn, T.S., 1962. *The Structure of Scientific Revolutions*. University of Chicago Press, Chicago.
- [15] Metcalfe, J.S., Mina, A., James, A. 2005. 'Emergent Innovation Systems and the Development of the Intraocular Lens', *Research Policy*. 34: 1283-1304.
- [16] Mina, A., Ramlogan, R., Tampubolon, G., Metcalfe, J.S. 2007. 'Mapping Evolutionary Trajectories: Applications to the Growth and Transformation of Medical Knowledge', *Research Policy* 36(5): 789-806.
- [17] Consoli, D. and R. Ramlogan 2012. Patterns of organization in the development of medical know-how: the case of glaucoma research. Forthcoming in *Industrial and Corporate Change*.

- [18] Consoli D, Ramlogan R, 2008. Out of sight: problem sequences and epistemic boundaries of medical know-how on glaucoma. *Journal of Evolutionary Economics*, 18(1):31–56
- [18] Merito M. and Bonaccorsi A. 2007. Co-evolution of physical and social technologies in clinical practice. The case of HIV treatments, *Research Policy*, 36(7), 1070-1087.
- [19] Yaqub, O. Knowledge Accumulation and the Development of Poliomyelitis Vaccines. STEPS Working Paper, 20.
- [20] Morlacchi, P., Nelson, R. 2011. How medical practice evolves: Learning to treat failing hearts with an implantable device. *Research Policy* 40(4): 511-525.
- [21] Nelson, R.R., Buterbaughb, K., Perl, M. and A. Gelijns, 2012. How medical know-how progresses. Forthcoming in *Research Policy*.
- [22] Gelijns, A. and N. Rosenberg, 1994. The Dynamics of Technological Change in Medicine. *Health Affairs* (Summer): 28-46.
- [23] Nelson, R.R., 2008. Factors affecting the power of technological paradigms. *Industrial and Corporate Change* 17(3): 485-497.
- [24] Nightingale, P. 2004. “Technological capabilities, invisible infrastructure and the un-social construction of predictability: the overlooked fixed costs of useful research”. *Research Policy* 33(9): 1259-1284.
- [25] Gelijns, A.C., Zivin, J., Nelson, R.R., 2001. Uncertainty and technological change in medicine. *Journal of Health Politics, Policy and Law*, 26:913–924.
- [26] Constant, E. 1980. The origins of the turbojet revolution. Johns Hopkins University Press, Baltimore

- [27] Vincenti, W., 1990. *What Engineers Know and How They Know It: Analytical Studies from Aeronautical History*. Baltimore: Johns Hopkins University Press.
- [28] Popper, K. 1959 *The Logic of Scientific Discovery*. New York: Basic Books.
- [29] Constant, E. 1973. A Model for Technological Change Applied to the Turbojet. Revolution. *Technology and Culture*, 14 (4):553-572
- [30] Laudan, R. (Ed.) 1984. *The Nature of Technological Knowledge. Are Models of Scientific Change Relevant?* Reidel, Dordrecht.
- [31] Vincenti, W., 1994. The retractable airplane landing gear and the Northrop "anomaly": Variation-selection and the shaping of technology. *Technology and Culture*, 35 (1): 1-33
- [32] Vincenti, W., 2000. Real-world Variation-selection in the Evolution of Technological Form: Historical Examples. In J. Ziman (ed.) *Technological Innovation as an Evolutionary Process*, New York: Cambridge University Press, 174-189.
- [33] Constant, E. 2000. Recursive practice and the evolution of technological knowledge. In Ziman, J. (Ed.) "Technological innovation as an evolutionary process" 219-233. Cambridge University Press, New York.
- [34] Nelson, R.R., 2006. Evolutionary social science and universal Darwinism. *Journal of Evolutionary Economics*, 16, 491-510.
- [35] Chai, J. 2000. Medical Device Regulation in the United States and the European Union: A Comparative Study. *Food and Drug Law Journal*, 55(1):57-80.

- [36] Dijk, M., Yarime, M.. 2010. The Emergence of Hybrid-Electric Cars: Innovation Path Creation through Co-Evolution of Supply and Demand. *Technological Forecasting and Social Change*, 77 (8), 1371-1390.
- [37] Avadikyan, A., Llerena, P. 2010. A real options reasoning approach to hybrid vehicle investments. *Technological Forecasting & Social Change* 77(4): 649–661
- [38] Sahal, D. 1985. Technological guideposts and innovation avenues. *Research Policy* 14: 61-82.
- [39] Sahal, D. 1985. Foundations of technometrics. *Technological Forecasting and Social Change* 27(1):1-37.
- [40] Peine, A. 2008. Technological paradigms and complex technical systems. The case of Smart Homes. *Research Policy* 37(3):508-529.
- [41] Pistorius, C., Utterback, J. 1997. Multi-Mode Interaction Among Technologies. *Research Policy*, 26(1): 67-84.
- [42] Islas, J. 1997. Getting Round the Lock-in in Electricity Generating Systems: The Example of the Gas Turbine' *Research Policy* 26: 49-66.
- [43] Geels, F.W. 2005. Technological transitions and system innovations: a co-evolutionary and socio-technical analysis. Edwar Elgar, Cheltenham.
- [44] Murmann, J.P., Frenken, K. 2006. Toward a Systematic Framework for Research on Dominant Designs, Technological Innovations, and Industrial Change', *Research Policy*, 35(7): 925-52.
- [45] Islas, J. 1999. The gas turbine: a new technological paradigm in electricity generation. *Technological Forecasting and Social Change*. 60 (2): 129–148.

- [46] Bresson, C. 1991. Technological Innovation and Long Wave Theory: Two Pieces of the Puzzle. *Journal of Evolutionary Economics* 1, 241–272.
- [47] Weightman, G. 2007. *The Industrial Revolutionaries. The Creation of the Modern World 1776-1914*. London, Atlantic Books.
- [48] Pérez, C. 2002. *Technological Revolutions and Financial Capital: The Dynamics of Bubbles and Golden Ages*, Edward Elgar, Cheltenham, U.K
- [49] Dew, N. Incommensurate technological paradigms? Quarreling in the RFID industry. *Industrial and Corporate Change*, 15 (5), 785-210.
- [50] Stark, D. (2009) *The Sense of Dissonance: Accounts of Worth in Economic Life*. Princeton University Press: Princeton and Oxford.
- [51] Maniadakis, A. and Gray, A. (2000) The economic burden of back pain in the UK. *Pain* 84: 95-103.
- [52] Duke University Medical Center (2004). Economic Impact Of Back Pain Substantial. *ScienceDaily*.
- [53] Weiner, B. 2007. Difficult medical problems: On explanatory models and a pragmatic alternative, *Medical Hypotheses*, 68:474–479.
- [54] Lieberman, I. 2004. Disc bulge bubble: spine economics 101. *The Spine Journal* 4(6): 609-613.
- [55] Singh, K., Vaccaro, A., Albert, T. 2004.. Assessing the potential impact of total disc arthroplasty on surgeon practice patterns in North America. *The Spine Journal*, 4(6), S195-S201.
- [56] Bono, C.M., Garfin, S.R. 2004. ‘History and Evolution of Disc Replacement’, *The Spine Journal*, 4: 145-150.

- [57] Mulholland, R.C. 2008. The myth of lumbar instability: the importance of abnormal loading as a cause of low back pain. *Euro Spine Journal*, 17:619–625.
- [58] Lee, C., Goel, V. 2004. ‘Artificial Disc Prosthesis: Design Concepts and Criteria’. *The Spine Journal* 4(6): S209-18.
- [59] Urbaniak, J.R., Bright, D.S., Hopkins, J.E. 1973. ‘Replacement of Intervertebral Discs in Chimpanzees by Silicondacion Implants: A Preliminary Report’. *Journal of Biomedical Material Research* 7: 165-86.
- [60] Le Huec, J.C., Kiaer, T., Friesem, T. 2003. ‘Shock Absorption in Lumbar Disc Prosthesis: A Preliminary Mechanical Study’. *Journal of Spinal Disorders & Techniques*, 28: 346-51.
- [61] Dahl, M.; Rouleau, J., Papadopoulos, S., Nuckley, D., Ching R. 2006. Dynamic Characteristics of the Intact, Fused, and Prosthetic-Replaced Cervical Disk. *Journal of Biomechanical Engineering*, 128(6):809-14
- [62] Büttner-Janz, K. 2003. ‘History’, in K. Büttner-Janz, S. Hochschuler and P. McAfee (eds) *The Artificial Disc*. Berlin: Springer, 1-10.
- [63] Levinthal, D. 1998. The Slow Pace of Rapid Technological Change: Gradualism and Punctuation in Technological Change. *Industrial and Corporate Change*, 7(2): 217-247
- [64] Miller, D. (2002) Orthopaedic product technology during the second part of the twentieth century. In “The Evolution of Orthopaedic Surgery”. Klenerman, L. (Ed.) Royal Society of Medicine Press, London.
- [65] Szpalski, M., Gunzburg, R., Mayer, M. 2002. ‘Spine Arthroplasty: A Historical Review’. *Euro Spine Journal*, Suppl 2: S65-84.

- [66] Mayer, H.M. 2005. 'Total Disc Replacement'. *Jone Bone Joint Surgical*, 87, 1029-37.
- [67] Kurtz, S.M. Total Disc Arthroplasty. In Kurtz, S.M., Edidin, A.A. *Spine Technology Handbook*. Academic Press, New York, 2006.
- [68] Mutescu, A. 2002. 'Interview with Dr Vincent Bryan'. *Argos Spine News*, 6(Oct.): 7-11.
- [69] Biondo, D., Lown, D. 2004. *Beyond Total Disc. The Future of Spine Surgery, Spine Industry Analysis Series*, New York: Viscogliosi Bros LLC.
- [70] Food and Drug Administration, 2009. Bryan Disc Approval Letter. From http://www.accessdata.fda.gov/cdrh_docs/pdf6/P060023a.pdf, retrieved 21 April 2010.
- [71] Enker, P., Steffee, A., McMillin, C., Keppler, L., Biscup R., Miller, S. (1993) Artificial disc replacement. Preliminary report with a 3-year minimum follow-up. *Spine*, 18(8), Pp. 1061-1070
- [72] Griffith, S. L., Shelokov, A.P., Shelokov A.P., Buttner-Janz, K., LeMaire, J.P., Zeegers, W.S. 1994. "A Multicenter Retrospective Study of the Clinical Results of the LINK SB Charite Intervertebral Prosthesis: The Initial European Experience". *Spine* 19:1842-1849.
- [73] Cummins, B., Robertson, J., Gill, S. 1998. Surgical experience with an implanted artificial cervical joint. *Journal of Neurosurgery*, 88:943-948.
- [74] Ulrich, K. The role of product architecture in the manufacturing firm. *Research Policy* 24 (1995) 419-441)
- [75] Arthur, W.B. 2009. *The Nature of Technology*. The Free Press, Nueva York.

- [76] Fraser, R.D., Ross, E.R., Lowery, G.L., Freeman, B.J. 2004. Lumbar disc replacement. AcroFlex design and results. *The Spine Journal*, 4:245S-251S.
- [77] Pimenta, L., Springmuller, R., Lee, C.K., Oliveira, L., Roth, S.E., Ogilvie, W.F. 2010. Clinical performance of an elastomeric lumbar disc replacement: Minimum 12 months follow-up. *SAS Journal*, 4:16–25
- [78] Naidu, S. 2007. In ‘Summary Minutes of the Orthopaedic And Rehabilitation Devices Panel Meeting’. July 17, 2007, Washington DC.
- [79] Henningfeld, C. (2005) Executive Interview. July. Orthoknow. Pp. 1-3.
- [80] Hummon, N.P, Doreian, P. 1989. ‘Connectivity in a Citation Network: The Development of DNA Theory’. *Social Networks*, 11: 39-63.
- [81] Verspagen, B. 2007. ‘Mapping Technological Trajectories as Patent Citation Networks: A Study on the History of Fuel Cell Research’. *Advances in Complex Systems*, 10(1):93-115.
- [82] Fontana, R., Nuvolari, A., Verspagen, B., 2009. Mapping technological trajectories as patent citation networks. An application to data communication standards. *Economics of Innovation and New Technology* 18 (4), 311–336.
- [83] Martinelli, A. 2008. ‘Technological Trajectories and Industry Evolution: The Case of the Telecom Switching Industry’. Paper presented at DRUID-DIME Academy Winter PhD Conference, Aalborg, 2 Jan.
- [84] Barberá, D., Jiménez, F., Castelló, I. 2011. Mapping the importance of the real world. The validity of connectivity analysis and the artificial disc. *Research Policy*, 40(3):473-486.

- [85] Hedge, D., Mowery, D., Graham, S. 2009. Pioneering Inventors or Thicket Builders: Which U.S. Firms Use Continuations in Patenting? *Management Science*, 55 (7): 1214-1226.
- [86] Utterback, J.M. 1996 *Mastering The Dynamics of Innovation*, Boston, Massachusetts: Harvard University Business School Press.
- [87] Adner, R., Snow, D. 2010. Old technology responses to new technology threats: demand heterogeneity and technology retreats. *Industrial and Corporate Change*, 19(5): 1655-1675
- [88] Rosenberg, N. 1976. On technological expectations. *The Economic Journal*, 86 (343): 523–535;
- [89] Simon, H.A. 1956. Rational choice and the structure of the environment. *Psychological Review*, 63 (2), 129-138.
- [90] Rosenberg, N. 1998. Chemical Engineering as a General Purpose Technology,” in Elhanan Helpman, ed., *General Purpose Technologies and Economic Growth*, Cambridge, Massachusetts: MIT Press.
- [91] Campbell, D.T., 1960 Blind Variation and Selective Retention in Creative Thought as in Other Knowledge Processes, *Psychological Review*, 67: 380-400.
- [92] Pickstone, J.V. 1993. Ways of knowing: towards a historical sociology of science, technology and medicine. *The British Journal for the History of Science*, 26: 433-458

Figures & Tables

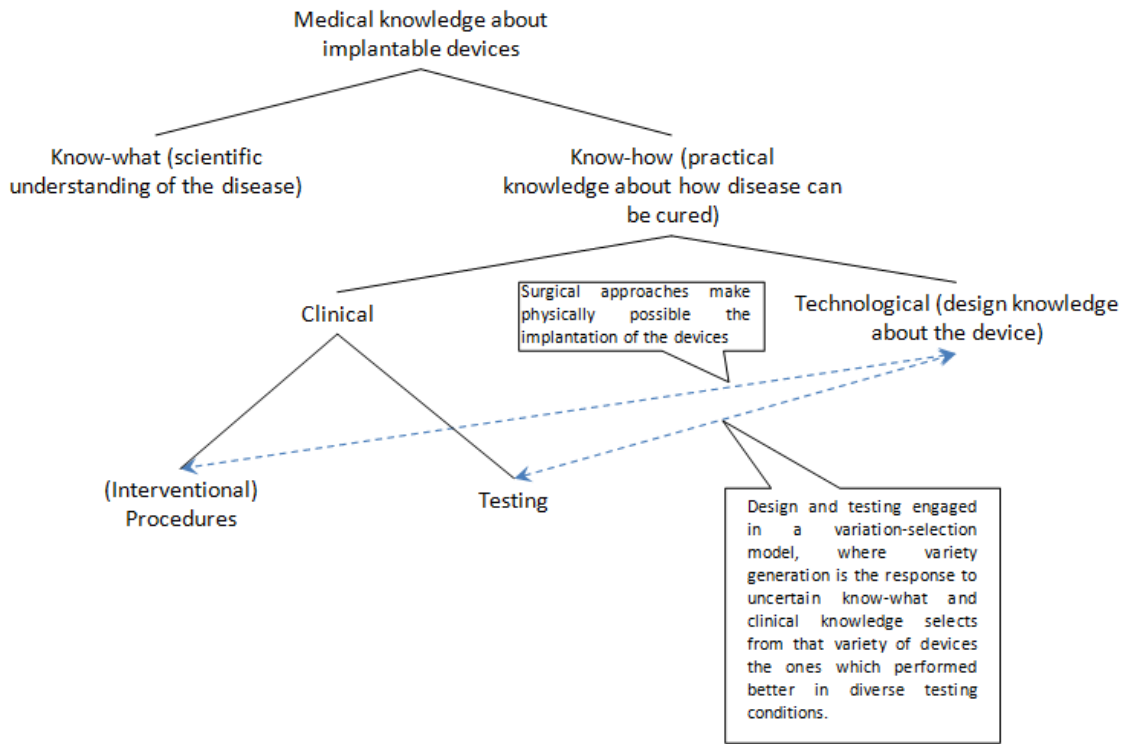

Figure 1. Typology of medical knowledge about implantable devices.

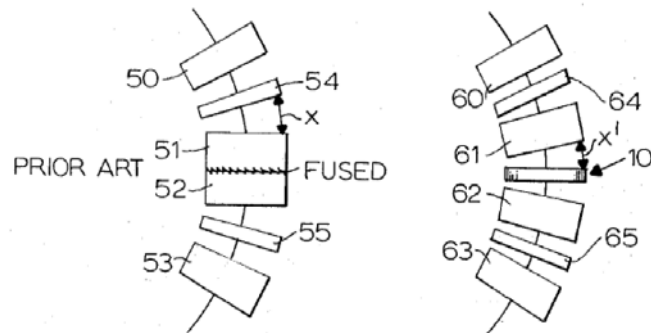

Figure 2: On the left, the fused vertebrae in an arthrodesis. On the center, the degenerated disc is replaced by a prosthesis. Source: US3867728

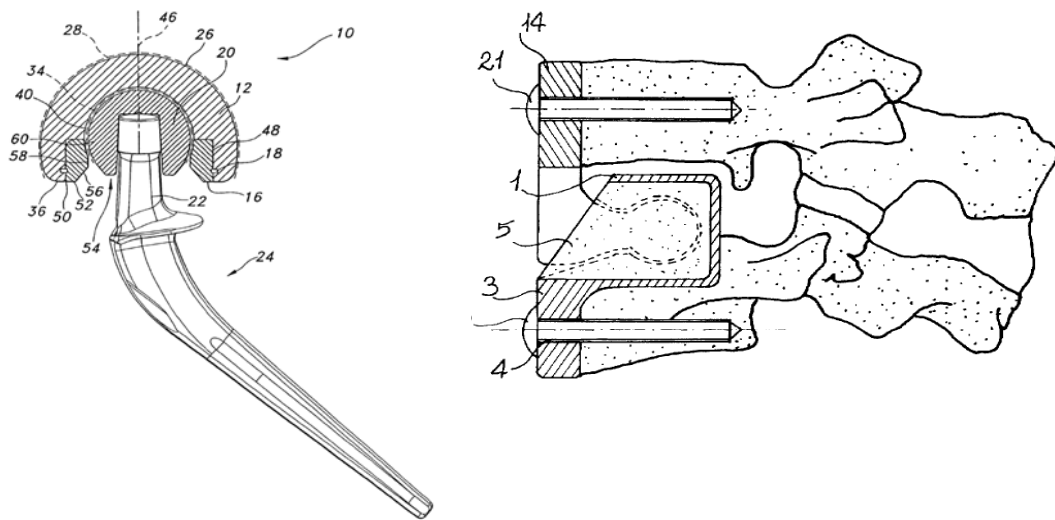

Figure 3. On the left, a hip prosthesis. On the right, a disc prosthesis following the ‘ball-and-socket’ principle of hip implants (Source: US6986792 and US5755796).

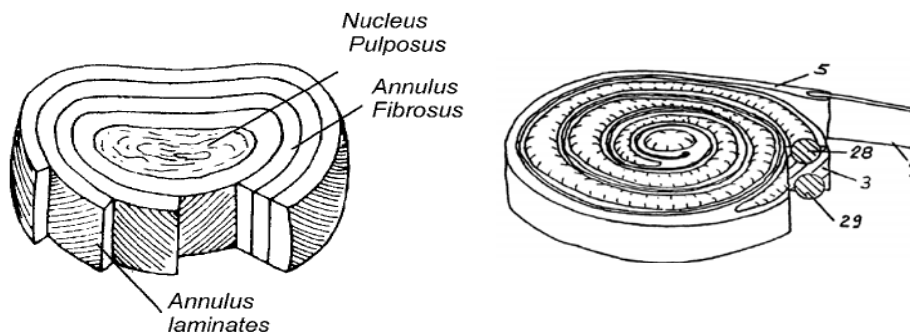

Figure 4. The diagram on the left shows an anatomic intervertebral disc. The diagram in the center shows a “mimetic design” based on the reproduction of the viscoelastic properties of the anatomical disc, using materials such as synthetic elastomers (Source: US6610094).

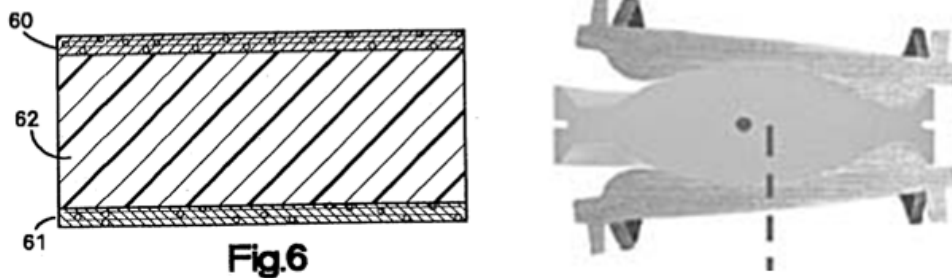

Figure 5. To the left, a classic elastomer/vertebral plates configuration of a mimetic patent related with the Acroflex project; to the right, a typical hip-like configuration (Source: US5071437).

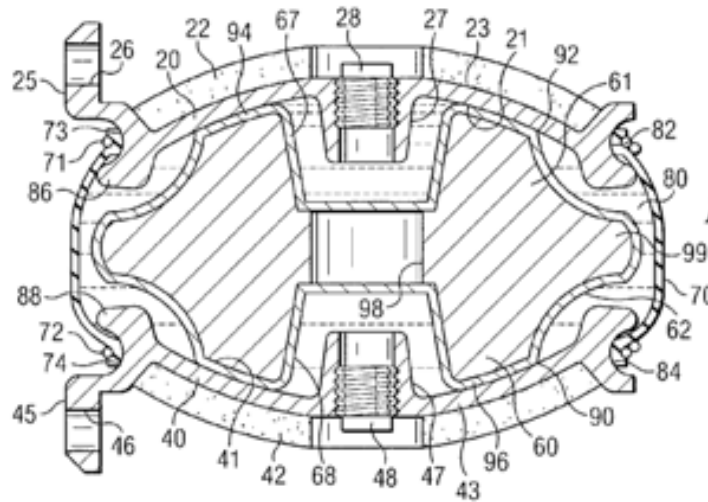

Figure 6. (Source: US7025787). Element 99 function is to absorb load, as in mimetic operational principle patents. However, instead of being joined to small plates 20 and 40, they move over them, as in hip-like patents. Element 70 is a membrane designed to avoid migration of particles from the movement of the articulation between 99 and 20-40.



Figure 8. A radiography of a Fernstrom ball 3 years after surgery. The steel ball has become encrusted in the bones because of the high pressure exerted in the original one-point contact between vertebrae and ball (source: [56]).



Figure 9. The Bryan artificial disc. Only the metallic vertebral plates and the external membrane can be seen .

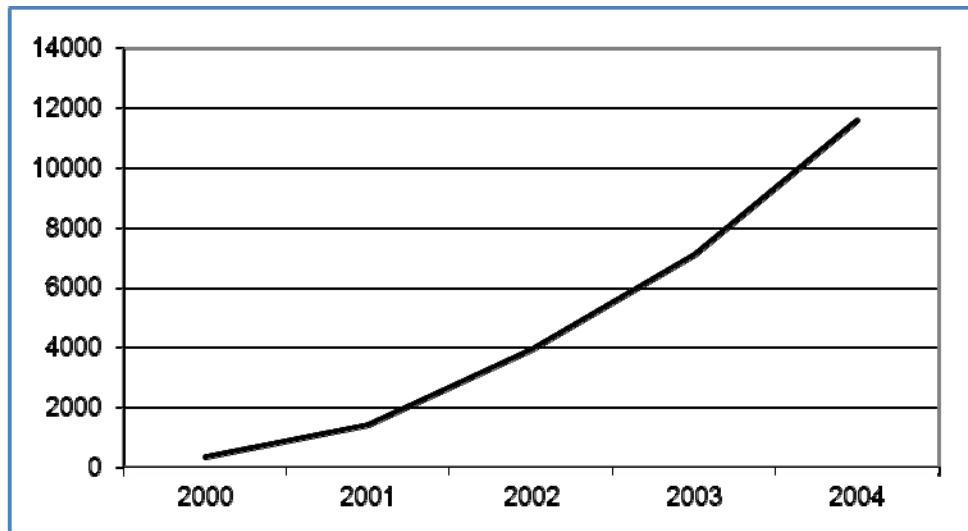

Figure 10. Sales evolution (in units sold) of artificial discs in 2000-2004. Source: own elaboration from data in [69].

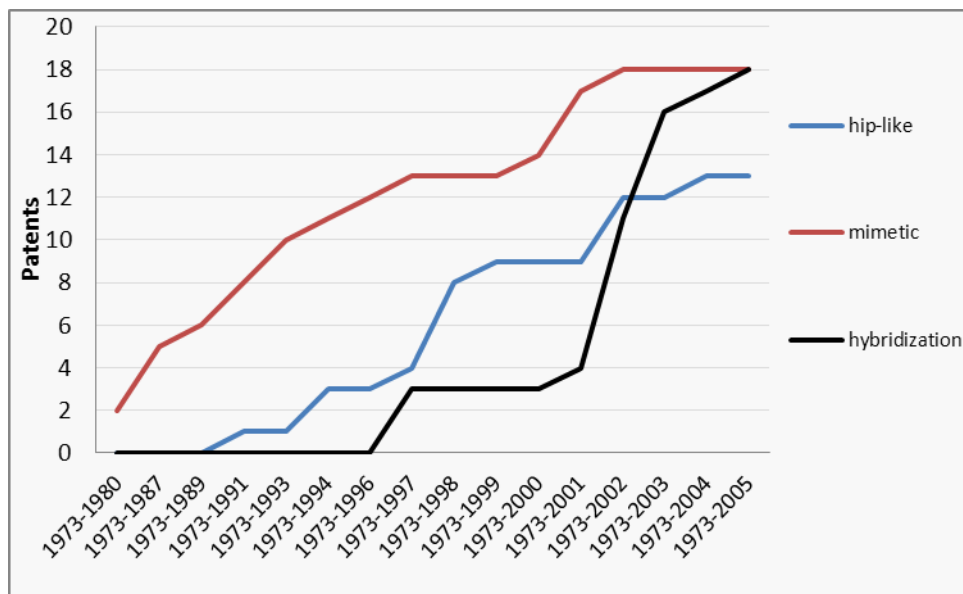

Figure 11. Number of granted patent of mimetic, hip-like and hybrid patents in the Network of the Evolution of Top Paths.

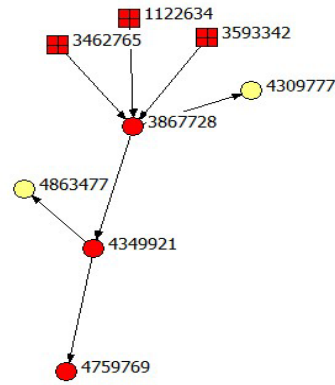

Figure 12: The Network of the Evolution of Top Paths (NETP) 1973-1987

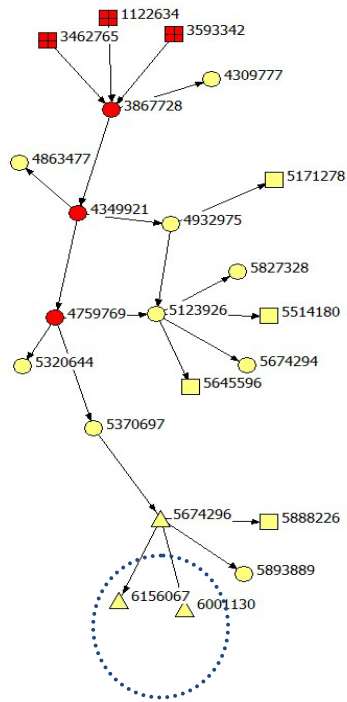

Figure 13: The Network of the Evolution of Top Paths (NETP) 1973-1997

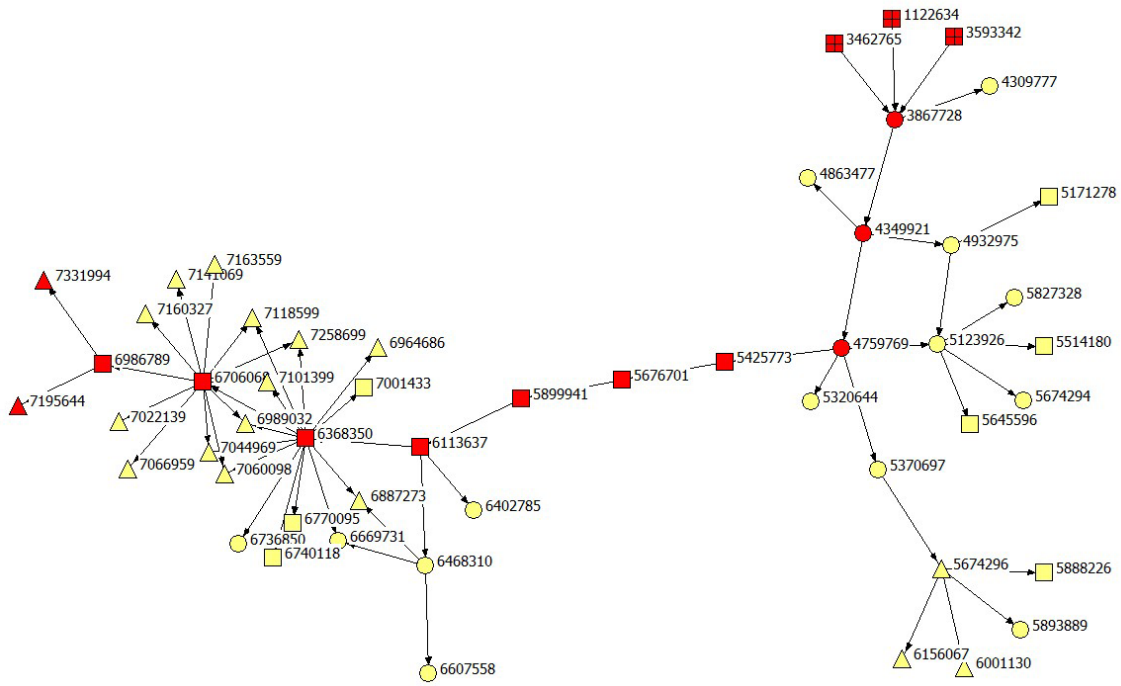

Figure 14: The Network of the Evolution of Top Paths (NETP) 1973-2004

	Design elements	Services	Comparative advantages	Comparative disadvantages
Mimetic	Sandwich configuration, with a constrained elastomer.	Motion and a presumable amount of load absorption.	A presumable amount of load absorption	(Early 90's) Negative experimental clinical results of the Acroflex disc, with systematic failure of the elastomer in the sandwich configuration.
Hip-like	Ball-and-socket articulation between rigid materials.	Motion	(Early 90's): - Positive clinical results of the SB Charité and Frenchay Hospital discs. - The ball-and-socket configuration avoids the constraints in the elastomer typical of mimetic designs.	No Load Absorption
Hybrid	Ball-and-socket articulation between an elastomer and 2 metallic plates.	Motion and a presumable amount of load absorption.	(Invented in mid 90's): - A presumable amount of load absorption - The ball-and-socket configuration avoids the constraints in the elastomer typical of the sandwich configuration in mimetic designs.	-

Table 1: Summary of Artificial Disk Design

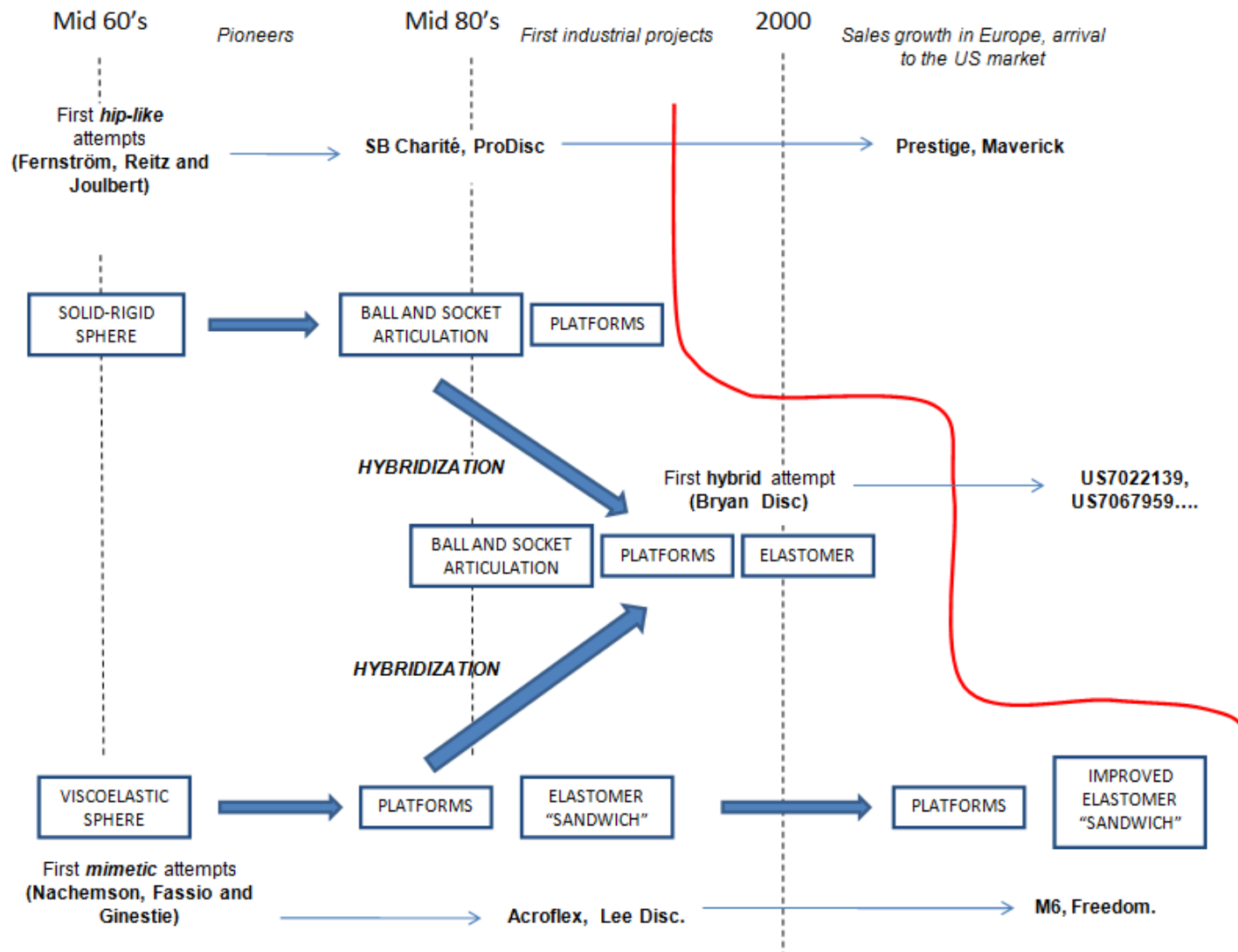

Figure 7. The evolution of the artificial disc. The red line marks the emergence of each operational principle in clinical use. Source: own elaboration from [67, 56, 65, 69, 77]